



INSTALLATION, OPERATION, AND MAINTENANCE MANUAL
WELKER® CRUDE OIL COLLECTION ASSEMBLY
HIGH PRESSURE

MODEL
AWL-3HP

DRAWING NUMBER
AD489AP

MANUAL NUMBER
IOM-116

REVISION
Rev. B, 7/18/2016

TABLE OF CONTENTS

	SAFETY	3
1.	PRODUCT INFORMATION	4
1.1	Introduction	4
1.2	Product Description	4
1.3	Specifications	5
1.4	Equipment Diagrams	6
2.	INSTALLATION & OPERATION	8
2.1	Before You Begin	8
2.2	Installation and Operation	8
2.3	Setting the Sample Volume	10
2.4	Verifying the Sample Volume	10
3.	MAINTENANCE	11
3.1	Before You Begin	11
3.2	Maintenance	12
	APPENDIX	14
	A: Referenced or Attached Documents	14

Welker®, Welker Jet®, WelkerScope®, and OdorEyes® are Registered Trademarks owned by Welker, Inc.

IMPORTANT SAFETY INFORMATION

READ ALL INSTRUCTIONS



Notes emphasize information and/or provide additional information to assist the user.



Caution messages appear before procedures that could result in damage to equipment if not observed.



Warning messages appear before procedures that could result in personal injury if not observed.

This manual is intended to be used as a basic installation and operation guide for the Welker® Crude Oil Collection Assembly, AWL-3HP. For comprehensive instructions, please refer to the IOM Manuals for each individual component. A list of relevant component IOM Manuals is provided in Appendix A of this manual.

The information in this manual has been carefully checked for accuracy and is intended to be used as a guide for the installation, operation, and maintenance of the Welker® equipment described in this manual. Correct installation and operation, however, are the responsibility of the end user. Welker reserves the right to make changes to this manual and all products in order to improve performance and reliability.

BEFORE YOU BEGIN

Read these instructions completely and carefully.

IMPORTANT - Save these instructions for local inspector's use.

IMPORTANT - Observe all governing codes and ordinances.

Note to Installer - Leave these instructions with the end user.

Note to End User - Keep these instructions for future reference.

Installation of this Crude Oil Collection Assembly is of a mechanical and electrical nature.

Proper installation is the responsibility of the installer. Product failure due to improper installation is not covered under the warranty.

If you received a damaged Crude Oil Collection Assembly, please contact a Welker® representative immediately.

Phone: 281.491.2331

Address: 13839 West Bellfort Street
Sugar Land, TX 77498

1.1 Introduction

We appreciate your business and your choice of Welker® products. The installation, operation, and maintenance liability for this equipment becomes that of the purchaser at the time of receipt. Reading the applicable *Installation, Operation, and Maintenance (IOM) Manuals* prior to installation and operation of this equipment is required for a full understanding of its application and performance prior to use.*

If you have any questions, please call Welker at 1-281-491-2331.

**The following procedures have been written for use with standard Welker® parts and equipment. Assemblies that have been modified may have additional requirements and specifications that are not listed in this manual.*

1.2 Product Description

The Welker® *AWL-3HP* Crude Oil Collection Assembly is a simple probe-mounted sampler designed for low-viscosity sampling applications.

The *AWL-3HP* is comprised of a Welker® *SP* Sample Probe, a Welker® Volume Regulator, and a 3-way ball valve with electric valve actuator. The sample volume of the Volume Regulator can be adjusted externally to collect up to 10 cc per actuation. The electric valve actuator connects to a customer Programmable Logic Controller (PLC) or other signal control system to operate the 3-way ball valve for timed or proportional to flow sample collection.



For this manual, the term "PLC," or Programmable Logic Controller, will be used to refer to the PLC, DCS, or other signal control system used by the customer to activate and operate the solenoid.

*Welker may custom design the *AWL-3HP* to suit the particular application and specifications of each customer.*

1.3 Specifications



The specifications listed in this section are generalized for this equipment. Welker can modify the equipment according to your company's needs. **Please note that the specifications may vary depending on the customizations of your equipment.**

Table 1: AWL-3HP Specifications

Products Sampled	Low Viscosity Liquids
Materials of Construction	316/316L Stainless Steel, PTFE, and Viton® Others Available
Maximum Allowable Operating Pressure	2160 psig @ -20 °F to 100 °F (148 barg @ -28 °C to 37 °C) Others Available
Connections	Pipeline: ½" MNPT or ¾" MNPT Sample Inlet: ¼" FNPT Sample Outlet: ¼" FNPT Others Available
Electrical Connection	DC 24 V AC 110 V
Sample Volume	0–10 cc
Features	3-Way Ball Valve With Electric Valve Actuator Welker® SP Sample Probe Welker® Volume Regulator
Option	Scooped Probe Tip

1.4 Equipment Diagrams

Figure 1: AWL-3HP Diagram

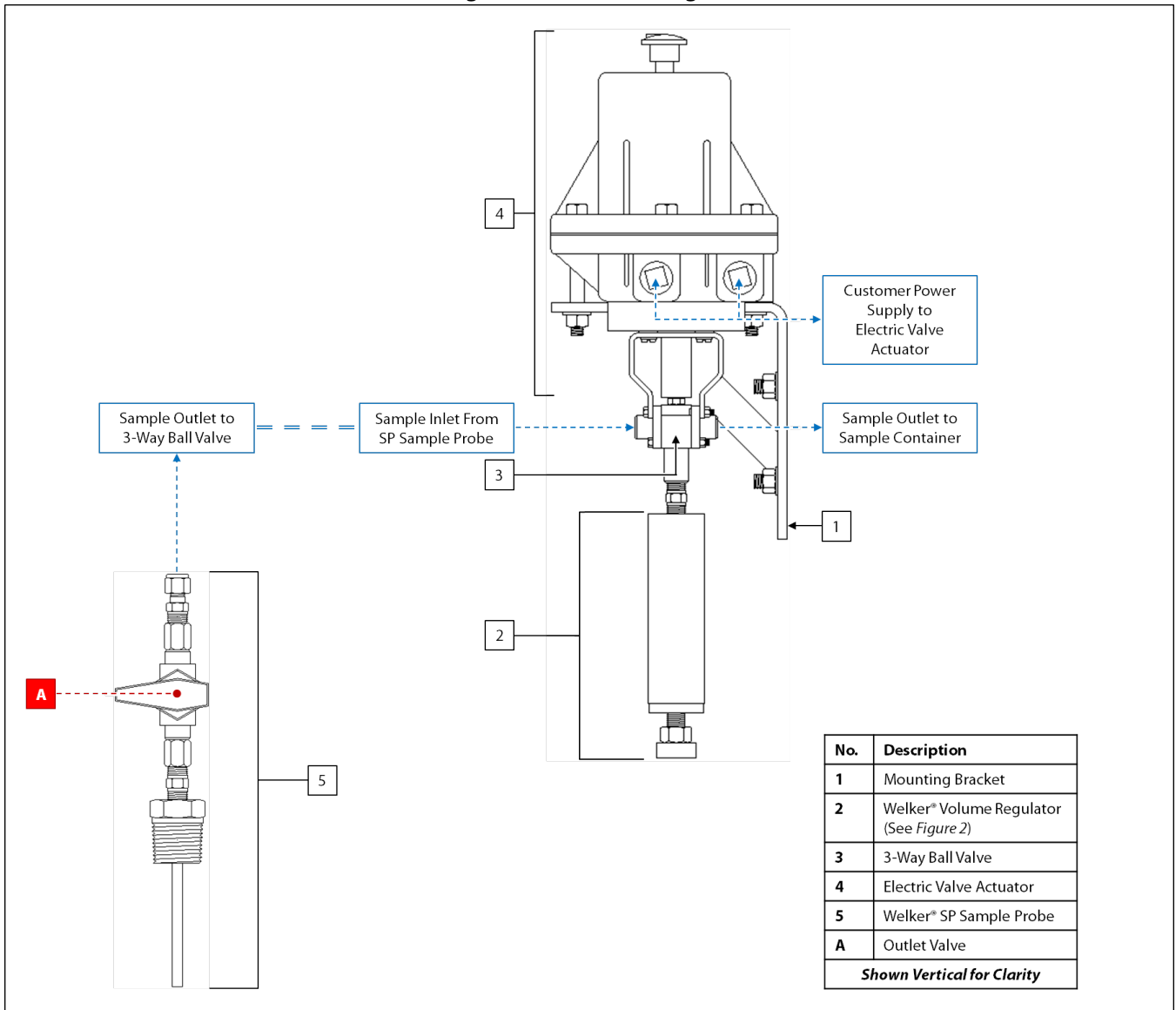
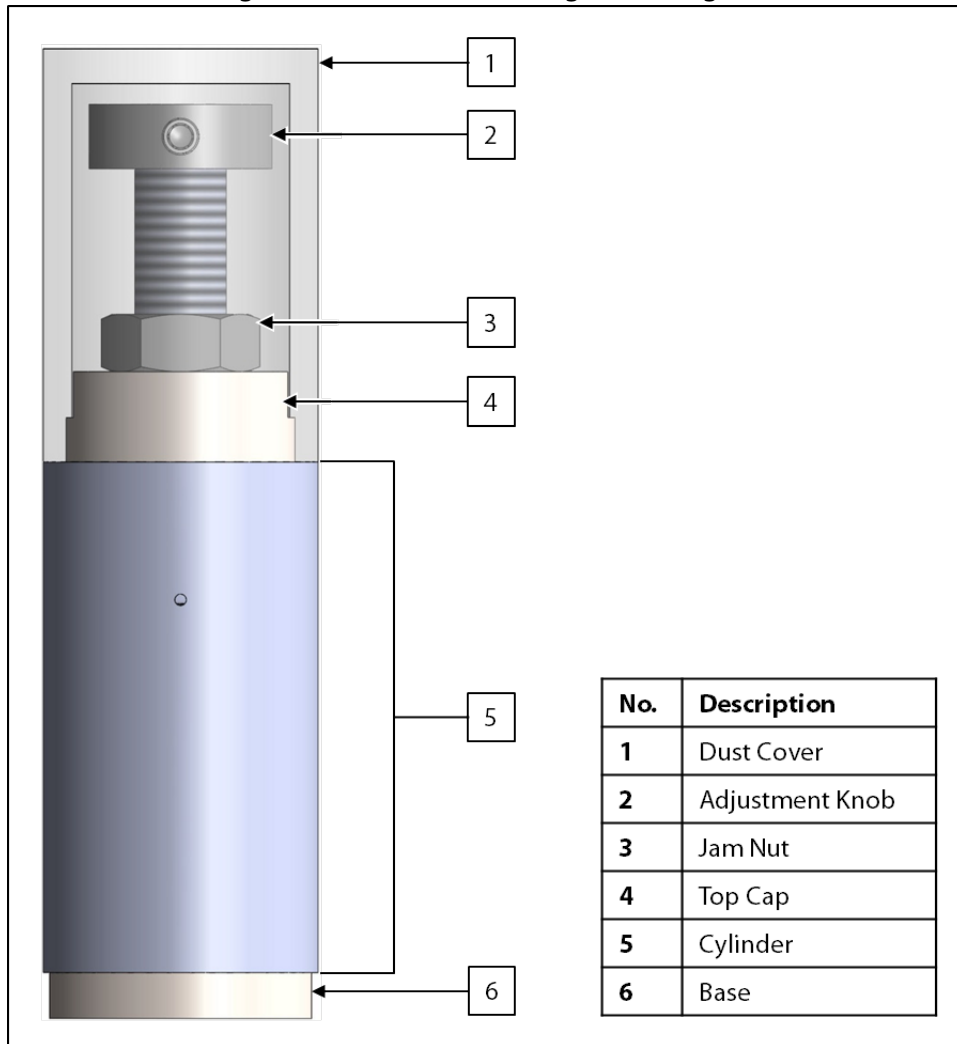

Figure 2: Welker® Volume Regulator Diagram



SECTION 2: INSTALLATION & OPERATION

2.1 Before You Begin



After unpacking the unit, check the equipment for compliance and any damage that may have occurred during shipment. Immediately contact a Welker® representative if you received damaged equipment.



When sealing fittings with PTFE tape, refer to the proper sealing instructions for the brand used.

1. Welker recommends that the probe be installed to the side of the pipe and inserted into the center one-third ($\frac{1}{3}$) of the pipeline in a location where the product is well-mixed and will yield an accurate and representative sample.
2. Locate the probe two to four pipe diameters (2-4D) downstream of an inline static mixer or other flow conditioning system.

2.2 Installation and Operation

1. Depressurize the pipeline.



The pipeline must be depressurized prior to installing and removing the unit.

2. Ensure that outlet valve A is closed (*Figure 1*).
3. As necessary, wrap the threads of the threaded pipeline connection with PTFE tape.
4. If the probe tip is scooped, determine the direction of product flow in the pipeline. For the AWL-3HP to function correctly, it must be installed so that the scooped probe tip is open against the direction of product flow.
5. Install the Welker® SP Sample Probe to the pipeline (*Figure 1*).
6. Mount the bracket on the 3-way ball valve with electric valve actuator to the pipeline (*Figure 1*).
7. Connect from the electric valve actuator to the customer PLC (*Figure 1*).
8. Using appropriately sized tubing, connect from the sample outlet on the SP to the sample inlet on the 3-way ball valve (*Figure 1*).
9. Using appropriately sized tubing, connect from the sample outlet to an atmospheric sample container (*Figure 1*).



Customer-supplied tubing must slope downward from the AWL-3HP to the sample container.

10. Set the sample volume on the Welker® Volume Regulator. See *Section 2.3, Setting the Sample Volume*, for instructions on setting the sample volume.
11. Pressurize the pipeline.
12. Open outlet valve A (*Figure 1*).

13. Set the PLC to the desired sampling frequency based on the sampling equations provided (Figure 3).

Figure 3: Sampling Frequency Equations

Liquid Sampling, Proportional to Flow Collection	
Equation 1: Number of Samples Needed	$\text{Number of Samples Needed to Fill to 80\%} = \frac{(\text{Container Size (cc)} * 0.8)}{\text{Bite Size (cc)}}$
Equation 2: Proportional-to-Flow	$\text{Volume of Flow Between Sample Grabs} = \frac{\text{Batch Size (Total Volume to be Sampled)}}{\text{Number of Samples Needed (Eq. 1)}}$
<p>Use Equation 1 to determine the number of actuations needed. Use Equation 2 to determine how often (after what volume of flow) to take each sample.</p>	
Liquid Sampling, Timed Collection	
Equation 1: Number of Samples Needed	$\text{Number of Samples Needed to Fill to 80\%} = \frac{(\text{Container Size (cc)} * 0.8)}{\text{Bite Size (cc)}}$
Equation 2: Timed Sampling	$\text{Time Between Sample Grabs} = \frac{\text{Total Time in Sample Period}}{\text{Number of Samples Needed (Eq. 1)}}$
<p>Use Equation 1 to determine the number of actuations needed. Use Equation 2 to determine how often (after what amount of time) to take each sample.</p>	



Never fill the container above 80% of its capacity. Allow at least 20% room for product expansion should the container be exposed to increased temperatures.



Note the 0.8 in Equation 1 represents the 80% volume limit for liquid sampling.



The Welker® Volume Regulator is adjustable between 0–10 cc per actuation.

14. From the PLC, energize the electric valve actuator and begin sampling.
 15. Continue sampling until the desired volume has been obtained.
 16. From the PLC, de-energize the electric valve actuator and halt sampling.

2.3 Setting the Sample Volume

1. Remove the dust cover from the top of the Volume Regulator (*Figure 2*).
2. Loosen the jam nut on the adjusting screw (*Figure 2*).
3. Screw the adjustment knob clockwise to set the sample volume at 0 cc.
4. Screw the adjustment knob counterclockwise to increase the sample volume to the desired amount (*Figure 2*).



One full rotation of the adjusting screw is approximately 0.9 cc.

5. Welker recommends verifying the sample volume prior to sampling. See *Section 2.4, Verifying the Sample Volume*, for instructions on verifying the sample volume.
6. Once the desired sample volume has been obtained, tighten the jam nut to secure the adjusting screw (*Figure 2*).
7. Return the dust cover to the Volume Regulator (*Figure 2*)

2.4 Verifying the Sample Volume

1. Ensure that the pipeline is pressurized.
2. As necessary, connect an atmospheric sample container to the sample outlet (*Figure 1*).
3. Decide how many actuations will be taken into the sample container to verify the sample volume.



Welker recommends a minimum of ten (10) actuations to verify the sample volume.

4. From the PLC, energize the electric valve actuator.
5. Capture product in the connected atmospheric sample container until the predetermined number of actuations has been taken.
6. Once the predetermined number of actuations has been taken, de-energize the electric valve actuator.
7. Disconnect the atmospheric sample container from the sample outlet.
8. Calculate the sample volume by dividing the volume of product captured in the atmospheric sample container by the number of actuations taken.
9. As necessary, adjust the sample volume on the Volume Regulator. See *Section 2.3, Setting the Sample Volume*, for instructions on setting the sample volume.

3.1 Before You Begin

1. **Welker recommends that the unit have standard yearly maintenance under normal operating conditions.** In cases of severe service, dirty conditions, excessive usage, or other unique applications that may lead to excess wear on the unit, a more frequent maintenance schedule may be appropriate.
2. Prior to maintenance or disassembly of the unit, it is advisable to have a repair kit available for repairs of the system in case of unexpected wear or faulty seals.



New seals supplied in spare parts kits should be lightly lubricated before being installed to ease the installation of the seals and reduce the risk of damage when positioning them on parts. Wipe excess lubricant from the seals, as it may adversely affect analytical instrument results.



For sample-exposed seals, Welker recommends non-hydrocarbon-based lubricants, such as Krytox®. For non-sample-exposed seals, Welker recommends either non-hydrocarbon-based lubricants or silicone-based lubricants, such as Molykote® 111.



After the seals are installed, the outer diameter of shafts and inner diameter of cylinders may be lubricated to allow smooth transition of parts.

3. All maintenance and cleaning of the unit should be performed on a smooth, clean surface.
4. Welker recommends having the following tools available for maintenance. Please note that the exact tools required may vary by model.
 - a. Adjustable Wrench (Qty. 2)
 - b. Crescent Wrench
 - c. Hex Key Set

3.2 Maintenance

1. Close outlet valve A (Figure 1).
2. Disconnect tubing from the sample inlet and sample outlet on the 3-way ball valve (Figure 1).
3. Disconnect the electric valve actuator from the customer PLC.
4. Unscrew the Volume Regulator from the 3-way ball valve.

Figure 4: Volume Regulator Maintenance Diagram

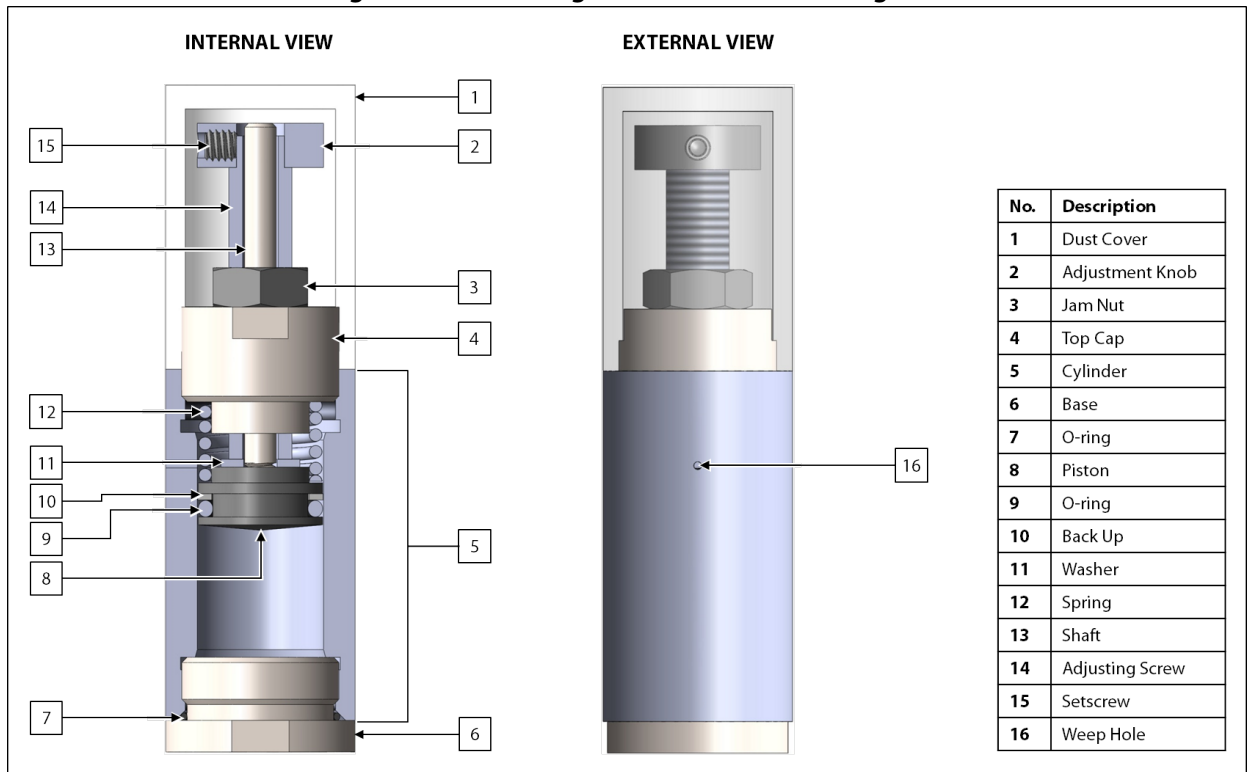

5. Remove the dust cover from the Volume Regulator.
6. Remove the setscrew from the adjustment knob, and then remove the adjustment knob from the adjusting screw.
7. Remove the jam nut from the adjusting screw.
8. Unscrew the adjusting screw from the top cap.
9. Unscrew the top cap from the cylinder.
10. Carefully pull the shaft from the cylinder. Note that the washer, spring, and piston will also be removed from the cylinder at this time.
11. Inspect the piston for scratches. Replace as necessary.
12. Inspect the shaft for scratches or other damage. Replace as necessary.
13. Replace the O-ring and back up on the piston.
14. Unscrew the cylinder from the base.
15. Clean the cylinder, and then inspect the inner diameter of the cylinder for scratches. If scratches are present, the cylinder needs to be replaced.
16. Replace the O-ring on the base.
17. Screw the cylinder onto the base.



The cylinder must be installed to the base with the weep hole pointing up to ensure the release of air from the cylinder as the piston moves. Installing the cylinder to the base with the weep hole pointing down will cause product to seep from the Volume Regulator.

18. Insert the piston with shaft and spring installed into the cylinder.
19. Screw the top cap into the cylinder.
20. Lightly lubricate the adjusting screw, and then screw the adjusting screw into the top cap.
21. Return the jam nut to the adjusting screw.
22. Return the adjustment knob to the adjusting screw.
23. Return the setscrew to the adjustment knob and tighten.
24. Return the dust cover to the Volume Regulator.
25. As necessary, refer to the *Installation, Operation, and Maintenance (IOM) Manual* for the 3-way ball valve for instructions on maintaining the valve.
26. As necessary, refer to the *Installation, Operation, and Maintenance (IOM) Manual* for the electric valve actuator for instructions on maintaining the actuator.
27. As necessary, refer to the *Installation, Operation, and Maintenance (IOM) Manual* for the Welker® SP Sample Probe for instructions on maintaining the probe.
28. Once maintenance has been performed on component parts, screw the Volume Regulator into the 3-way ball valve.
29. The AWL-3HP is now ready to be returned to service. See *Section 2.2, Installation and Operation*, for instructions on returning the unit to operation.



Check valves for leaks and repair as necessary during reinstallation.

APPENDIX A: REFERENCED OR ATTACHED DOCUMENTS

Welker® *Installation, Operation, and Maintenance (IOM) Manuals* suggested for use with this unit:

- IOM-035: Welker® SP-1, SP-1W, SP-2, SP-3, and SP-5 Sample Probes
- IOM-105: Welker® NV-1 and NV-2 Instrument Valves

Other *Installation, Operation, and Maintenance (IOM) Manuals* suggested for use with this unit:

- Emerson Bettis™ E/M Switch Kit (Welker® IOM-V003)
- Emerson Bettis™ TorqPlus™ Electric Valve Actuators (Welker® IOM-V002)
- Hy-Lok Corporation 110 Series Ball Valves (Welker® IOM-V292)
- Swagelok® One-Piece Instrumentation Ball Valves 40G Series and 40 Series (Welker® IOM-V085)
- Parker Skinner™ 71313, 71315, 71335, 71385, 71395, 7131V, and 7133V 3-Way Solenoid Valves (Welker® IOM-V016)
- Valpes Valve Control System VR 25-45-75 Electric Actuator (Welker® IOM-V027)
- Valpes Valve Control System VRX 25-45-75 Electric Actuator (Welker® IOM-V023)
- Valpes Valve Control System VRX/VSX 25–300 Electric Actuator (Welker® IOM-V172)

Welker® drawings and schematics suggested for use with this unit:

- Assembly Drawing: AD489AP

